

# R 5

## Rotary Vane Vacuum Pumps RA 0160–0302 D



- › **Reliable:**  
robust construction, reliable operation, highly resilient carbon fibre vanes, proven performance, over 3 million pumps in operation
- › **High Performance:**  
high pumping speed and low ultimate pressure, designed for continuous operation
- › **Flexible:**  
application-oriented, various design options available, easy adaption to individual customer requirements and processes
- › **Low Operating Costs:**  
energy-efficient, optimum cost-benefit ratio
- › **Easy Servicing:**  
easy service routine

The R 5 RA 0160–0302 D belong to the Busch product family of proven R 5 rotary vane vacuum pumps. They have been specially designed for continuous operation in vacuum packaging machines.

Robustness and reliability of operation are the outstanding qualities of R 5 rotary vane vacuum pumps. These are just some of the reasons why proven Busch rotary vane technology has long established itself as the industry standard. Over 3 million R 5 rotary vane vacuum pumps are in operation worldwide in industry every day.

Rotary vane technology has been continuously developed and optimized by Busch in the course of over 50 years, always with a strong focus on economy and reliability of operation. High efficiency is the benefit of this continual development.

R 5 rotary vane vacuum pumps are characterized by high pumping speeds even in low pressure ranges and therefore rapid evacuation times. They feature highly durable Busch carbon fibre composite vanes as standard, ensuring optimum performance together with long service life. The specially designed exhaust filters provide excellent oil separation.

Maintenance can easily be carried out by the operator. Apart from changing oil and filters at regular service intervals, no further maintenance is required.

R 5 rotary vane vacuum pumps stand for advanced and energy-efficient vacuum generation in a wide variety of applications in industry throughout the world. You can always rely on the R 5 – whether used intermittently or around the clock.

**R 5 – proven and reliable.  
Over 3 million pumps  
in operation worldwide.**



# R 5

## Rotary Vane Vacuum Pumps RA 0160–0302 D



### Technical specifications

Rotary vane technology is synonymous with a robust, functional construction. R 5 rotary vane vacuum pumps are characterized by an optimum design and perfectly synchronized components and materials. The constantly high vacuum level in continuous operation is ensured by recirculating oil lubrication and state-of-the-art precision manufacturing. A sophisticated oil separator ensures efficient use of oil. When fitted with a gas-ballast valve (optional), even large quantities of vapour can be extracted. A non-return valve in the inlet flange prevents the pumped medium from flowing back into the vacuum process after the vacuum pump is switched off. The R 5 RA 0160–0302 D are driven by a directly flange-mounted standard electric motor, with an efficiency class of IE3.

### Accessories / Technical options

- Gas-ballast valve
- Various inlet filters
- Adapter flange for vacuum booster
- Energy recuperation kit with heat exchanger
- Oil level switch
- Filter pressure sensors
- Temperature sensors
- Starter unit
- Vacuum pump oils for all applications

R 5 RA 0160–0302 D

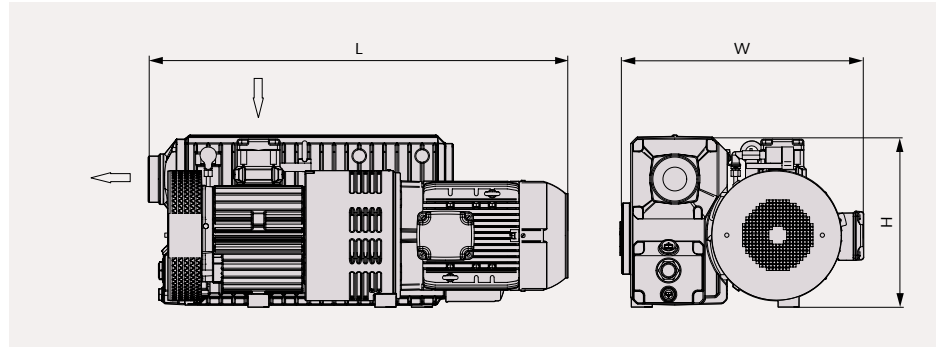

### Pumping speed

Air at 20 °C. Tolerance: ± 10% — 50 Hz - - - - 60 Hz

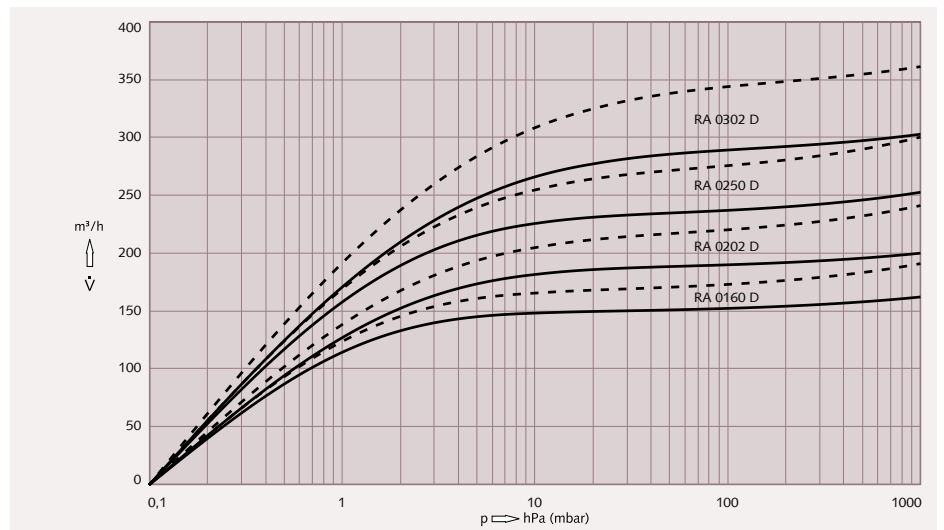

Technical data			RA 0160 D	RA 0202 D	RA 0250 D	RA 0302 D
Nominal pumping speed	50 Hz / 60 Hz	m³/h	160 / 190	200 / 240	250 / 300	300 / 360
Ultimate pressure gas-ballast valve closed	50 Hz / 60 Hz	hPa (mbar)	0.1	0.1	0.1	0.1
Ultimate pressure gas-ballast valve open	50 Hz / 60 Hz	hPa (mbar)	0.5	0.5	0.5	0.5
Nominal motor rating	50 Hz / 60 Hz	kW	4.0 / 6.6	4.0 / 6.6	5.5 / 9.2	7.5 / 9.2
Nominal motor speed	50 Hz / 60 Hz	min <sup>-1</sup>	1500 / 1800	1500 / 1800	1500 / 1800	1500 / 1800
Power consumption at 100 mbar	50 Hz / 60 Hz	kWh	3.7 / 4.7	4.4 / 5.4	5.8 / 7.0	6.3 / 7.8
Power consumption at ultimate pressure	50 Hz / 60 Hz	kWh	2.6 / 3.1	3.5 / 4.2	4.5 / 5.5	5.0 / 5.8
Noise level (ISO 2151)	50 Hz / 60 Hz	dB(A)	70 / 72	72 / 74	72 / 74	74 / 76
Oil capacity		l	5	5	6,5	6,5
Weight approx.*		kg	140	140	190	190
Dimensions (L x W x H)*		mm	920 x 536 x 410	920 x 536 x 410	1000 x 581 x 410	1011 x 581 x 410
Gas inlet/outlet			G 2" / G 2"	G 2" / G 2"	G 2" / G 2"	G 2" / G 2"

\*values may vary slightly due to different motor versions