

Mink

Claw Compressors MM 1202 - 1322 AP



Mink claw compressors have been specially developed to provide reliable compression of air and other gases. Mink claw technology guarantees efficient and constant supply of overpressure of up to 2 bar(g) for many industrial applications.

Clean compressed air

Thanks to the state-of-the-art claw technology, the gas is compressed in a non-contact and totally oil-free process. This dry compression means that the gas doesn't get contaminated and can be used in further processes without being filtered or cleaned.

Application-orientated

Through the drive motor selection the performance of Mink claw compressors can be adapted between 0.7 and 2.0 bar(g) for each particular application through the drive selection. This enables an efficient generation of blast and compressed air.

Minimum maintenance effort

An additional benefit of claw technology is the virtually maintenance-free operation due to the oil-free, non-contact operating principle. The need for maintenance, such as the inspection or replacement of worn parts and operating fluids, is completely eliminated. Mink claw compressors are air-cooled.

The excellent reliability and long life cycle of Mink claw compressors are also a result of the oil-free and non-contact compression. Due to the wear-free operation, the volumetric flow and overpressure remain consistently high throughout the life cycle of the compressor. An ingenious silencing concept enables quiet operation.



**Mink – efficient and reliable
compressed air generation.**



Mink

Claw Compressors MM 1202 - 1322 AP



Technical specification

With Mink compressors, two claw-shaped rotors turn in opposite directions inside the housing. Due to the shape of these claw rotors, the air or gas is sucked in, compressed and discharged. The claw rotors do not come into contact either with each other nor with the cylinder in which they are rotating. Tight clearances between the claw rotors and the housing optimise the internal seal and guarantee a consistently high volume flow.

A synchronisation gearbox ensures exact synchronisation of the claw rotors.

Mink compressors are driven by a directly flange-mounted asynchronous motor, with an efficiency class IE2.

Mink claw compressors are fitted as standard with an inlet filter and a pressure relief valve. There is a total of eight different sizes of Mink claw compressor to choose from, from 62 to 500 m³/h.

Contact us.

Our application specialists are happy to advise you.

Mink MM 1202 - 1322 AP

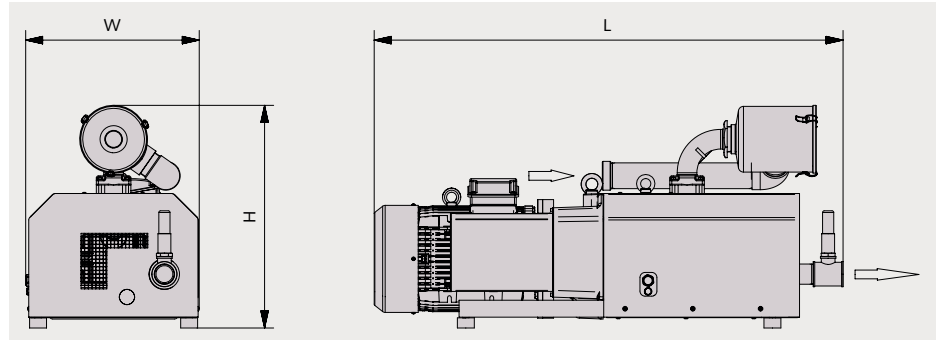

Volume flow

Air at 20 °C. Tolerance: ± 10% — 50 Hz - - - - 60 Hz

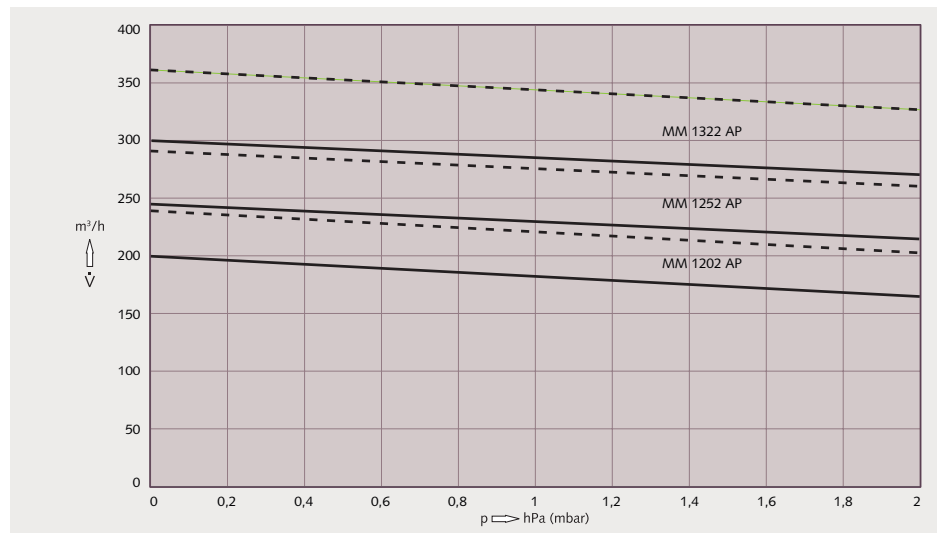

Technical Data			MM 1202 AP			MM 1252 AP			MM 1322 AP		
Volume flow	50 Hz / 60 Hz	m ³ /h	200 / 240			245 / 290			300 / 360		
Over pressure	50 Hz	bar	0,7	1,2	2,0	0,9	1,6	2,0	1,0	1,7	2,0
Nominal motor rating	50 Hz	kW	6,0	7,5	11,0	7,5	11,0	15,0	11,0	15,0	18,5
Over pressure	60 Hz	bar	1,0	1,8	2,0	0,7	1,4	2,0	0,8	1,5	2,0
Nominal motor rating	60 Hz	kW	9,5	12,6	17,3	9,5	12,6	17,3	12,6	17,3	22,0
Nominal motor speed	50 Hz / 60 Hz	min ⁻¹	3000 / 3600			3000 / 3600			3000 / 3600		
Noise level (ISO 2151)	50 Hz / 60 Hz	dB(A)	80 / 83			81 / 84			82 / 85		
Weight approx.		kg	210			230			255		
Dimensions	L x W x H	mm	1265 x 515 x 665			1380 x 515 x 665			1435 x 515 x 665		
Gas outlet		G	2"			2"			2"		

* Complies with accuracy class 2 at operating point of 1.0 bar(g)

Busch (UK) Ltd.

Hortonwood 30 | Telford, Shropshire, TF1 7YB | Phone +44 (0)1952 67 74 32 | sales@busch.co.uk | www.busch.co.uk

Argentina Australia Austria Belgium Brazil Canada Chile China Czech Republic Denmark Finland France Germany Hungary India Ireland Israel Italy Japan Korea Malaysia Mexico New Zealand Netherlands Norway Poland Portugal Russia Singapore South Africa Spain Sweden Switzerland Taiwan Thailand Turkey United Arab Emirates United Kingdom USA

Technical data is subject to change. Created in Germany 02/0