

# Fossa

Scroll Vacuum Pumps  
FO 0015/0035 A



**Hermetically sealed, 100% oil free** and ideal for pumping air or conveying gases without leakage or ambient air contamination – the Fossa scroll vacuum pump.

Two standard sizes are available: FO 0015 A and FO 0035 A. Featuring consistently high vacuum levels and with very low noise and vibration levels, these pumps are ideal for today's analytical and scientific applications. Thanks to its compact design, the Fossa scroll vacuum pump requires no special mounting making setup quick and easy while also providing a high degree of pump mobility.

The low noise and vibration levels make the Fossa vacuum pumps suitable for use in areas such as laboratories. With no shaft seals and with lifetime-lubricated bearings, the Fossa vacuum pump requires very little maintenance. Its high level of efficiency ensures maximum suction capacity with low energy consumption. The standard gas-ballast valve enables the pumping of vapours.

Fossa scroll vacuum pumps are the perfect solution for backing of turbomolecular pumps. They are ideally suited for generating fine vacuum in load lock or transfer chambers, helium leak detectors, mass spectrometers, electron microscopes and other analytical devices. They are also used in processes for handling of gases which require the highest level of purity within the gas recovery process.



**Fossa – Hermetically sealed.  
Quiet and low  
vibration levels.**



# Fossa

## Scroll Vacuum Pumps FO 0015/0035 A



### Technical specifications

The Fossa scroll vacuum pump consists of both a fixed and an orbiting scroll. As the orbiting scroll moves, voids are created at the inlet of the pump, drawing in the gas. As the rotor further moves, the gas is steadily compressed until it is discharged to atmosphere at the pump exhaust.

The scroll pump design provides 100% oil-free operation as it does not require any lubrication. The bearings are separated from the compression chamber so no contamination of the pumped gas is possible. In addition, the leak-tight design ( $\leq 1 \times 10^{-6}$  mbar l/s) helps prevent contamination of the pumped gas by ambient air.

Maintenance is limited to changing the scroll tip seals which can be easily done by the operator and without the need for special tools.

### Accessories/technical options

- Gas-ballast valve - delivered by default, but unassembled
- Standard connector (IEC EN60320 C13, single phase motor only)

### FO 0015/0035 A

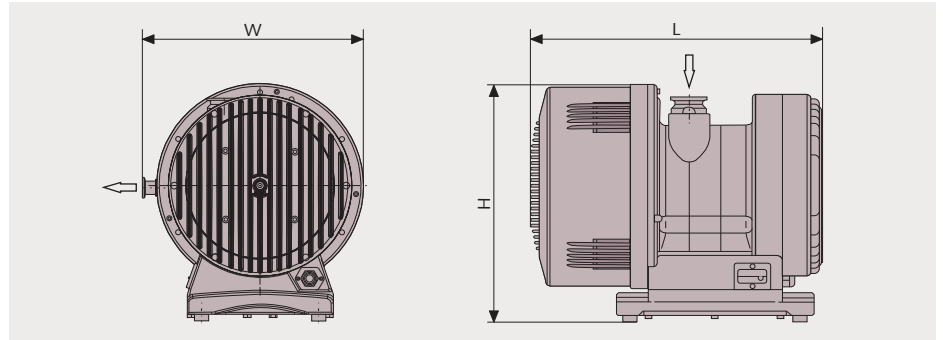

### Pumping speed

Air at 20 °C. Tolerance:  $\pm 10\%$  — 50 Hz - - - - 60 Hz

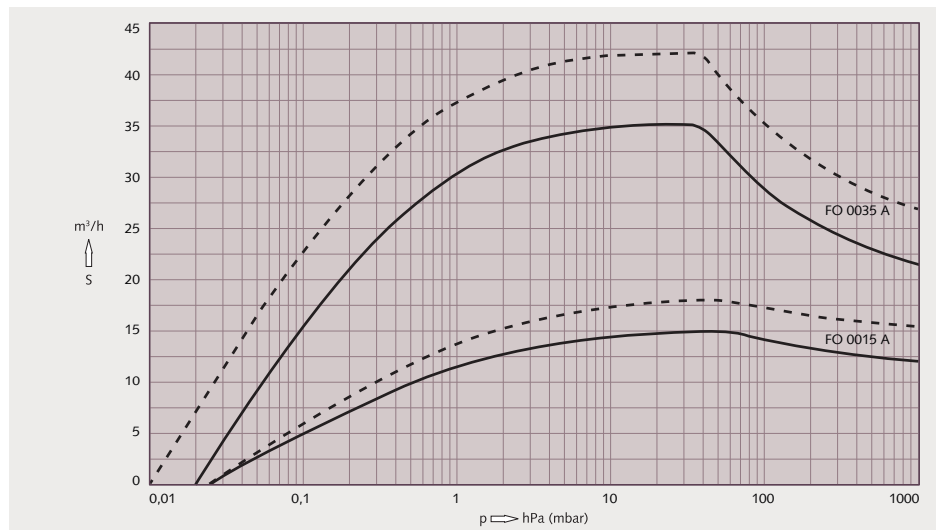

Technical Data			FO 0015 A	FO 0035 A
Max. pumping speed	50 Hz / 60 Hz	m <sup>3</sup> /h	15 / 18	35 / 42
Ultimate pressure	50 Hz / 60 Hz	hPa (mbar)	$\leq 2.5 \cdot 10^{-2}$	$\leq 2.0 \cdot 10^{-2} / \leq 1 \cdot 10^{-2}$
Leak rate		mbar l/s	$\leq 1 \cdot 10^{-6}$	$\leq 1 \cdot 10^{-6}$
Nominal motor rating	50 Hz / 60 Hz	kW	0.4	0.75
Nominal motor speed	50 Hz / 60 Hz	min <sup>-1</sup>	1480 / 1780	1480 / 1780
Motor supply voltage		V	1 x 100-115 / 50-60 Hz 1 x 200-240 / 50-60 Hz 3 x 190-240 / 380-415 / 50-60 Hz	3 x 380-415 / 50 Hz (built-in motor protection) 3 x 190 -220 / 50-60 Hz (built-in motor protection) 3 x 190-240 / 380-415 / 50-60 Hz
Noise level (ISO 2151)	50 Hz / 60 Hz	dB(A)	< 57 / < 59	< 62 / < 63
Weight approx.		kg	48	50
Dimensions	L x W x H	mm	450 x 338 x 369	462 x 338 x 369
Gas inlet / outlet		ISO-KF	DN 40 / DN 16	DN 40 / DN 16

### Dr.-Ing. K. Busch GmbH

Schauinslandstraße 1 | 79689 Maulburg | Tel. +49 (0)7622 681-0 | info@busch.de | www.busch.de

Argentina Australia Austria Belgium Brazil Canada Chile China Czech Republic Denmark Finland France Germany Hungary India Ireland Israel Italy Japan Korea Malaysia Mexico New Zealand Netherlands Norway Poland Portugal Russia Singapore South Africa Spain Sweden Switzerland Taiwan Thailand Turkey United Arab Emirates United Kingdom USA

Technical data is subject to change. Created in Germany 02/0